

# LIFT-A-LOFT *DPL Series*

## *Disabled Passenger Lift (DPL)*



### *Safe, Comfortable and Easy to Operate*

The Lift-A-Loft DPL Series provides a safe, comfortable and dignified means to assist passengers with mobility impairments in the enplaning/deplaning of aircraft.

These self-propelled units are designed to interface small commuter aircraft as well as many narrow bodied jets. This includes aircraft such as the ATR, Beech 1300/1900, Saab 340, Shorts 330/360, Dash 7/8, EMB 110/120, Fokker 27/28/100, Jetstream 31/41, Metro 3, Twin Otter, King Air, BAE 146, CRJ, Dornier, Boeing 727/737, DC 9, MD 80/90 and more.

The DPL Series can be driven from terminal to boarding area. Units can also facilitate the moving of passengers from jetway to boarding area when elevator or ramps are not available.

### *Providing Equal Access*

- *Safe, Comfortable Boarding*
- *One Person Operation*
- *2nd Level Access*
- *Proven Design*
- *Easy to Maneuver*
- *AIP/PFC Eligible*



# **LIFT-A-LOFT**

*An Industry Leader for 50 Years*

# -DPL Series

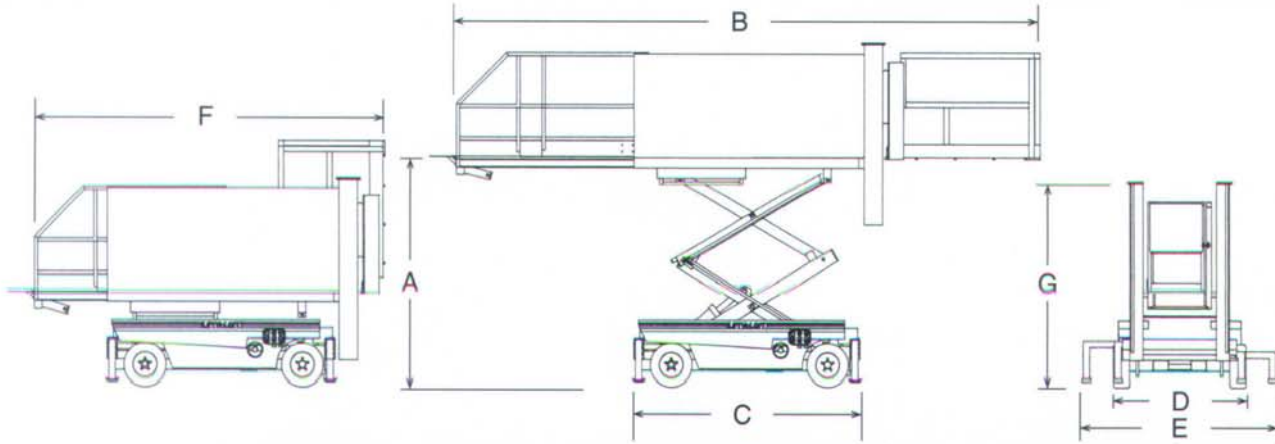

MODEL	A	B	C	D	E	F	G
	Max. Plat. Ht	Overall Length (Extends deck out access platform in place)	Base Length	Base Width (Outriggers retracted)	Base Width (Outriggers deployed)	Stowed Length	Lowered Height
<b>SPDPL</b> <small>(Self-Propelled, Electric, Commuter Aircraft Only)</small>	80" 2.03m	190" 4.83m	92" 2.34m	48" 1.22m	74" 1.88m	104" <sup>**</sup> 2.64m	88" <sup>*</sup> 2.23m
<b>SPEDPL</b> <small>(Self-Propelled, Electric)</small>	126" 3.20m	244" 6.20m	103" 2.61m	75" 1.90m	96" 2.44m	130" <sup>**</sup> 3.30m	88" <sup>*</sup> 2.23m
<b>SPGDPL</b> <small>(Self-Propelled, Gas)</small>	126" 3.20m	244" 6.20m	103" 2.61m	75" 1.90m	96" 2.44m	130" <sup>**</sup> 3.30m	88" <sup>*</sup> 2.23m

\* Note: Add 30" (.76m) for canopy    \*\* Note: Add 56" (1.66m) with access platform lowered

## Specifications

### PERFORMANCE\*

**Platform Capacity:** 650 lbs.

**Platform Lift Speed:**

**Access Platform** - .125 fps

**Main Platform** - .2 fps

**Travel Speed:** Proportional

**Lowered** - .1 to 2.2 mph

**Elevated** - .1 to .7 mph

**Brakes:** Spring applied, pressure release

### STANDARD COLORS

Wimbledon White or Smoke Gray

### POWER SOURCE

**Self-Propelled, Electric:**

(4) 6 Volt deep cycle 225 AHC batteries provides 24 Volt system with on-board 110 Volt AC 60 HZ fully-automated charger

**Self-Propelled, Gas:**

20 HP air-cooled internal combustion engine

\*All performance characteristics given here are average and may be affected by operating conditions at your facility. Specifications subject to change without notice.

### FEATURES

- Ground Level Access
- 2nd Level Access
- Easy to Maneuver
- Proven Design
- Proportional Controls

### OPTIONS

- Platform Canopy
- Boarding Chair
- Pressure-Sensitive Trip Bumper
- Special Custom Paint

### BENEFITS

- Safe, comfortable boarding
- Carries passengers from the Jetway to Aircraft
- Precision positioning for set up
- Reliable, easy to maintain
- Variable Speed for Precision Alignment

- Adjustable Lights
- Hydraulic System Heater
- Head Lights & Tail Lights

# LIFT-A-LOFT