

# MWS16



**MWS16**  
**C130 Turbine Removal/Replacement**  
**Maintenance & Fuel Pod Installation Tool**



# MWS16

Lift-A-Loft's MWS16 maintenance/service platform was developed from the most proven design in scissor mechanisms and safety devices. The unit is drivable and steerable at all elevations allowing easy positioning of unit and reduced setup time. This unit is designed for maintenance of C130 aircraft, replacing and positioning of engine turbines, and external fuel tanks.

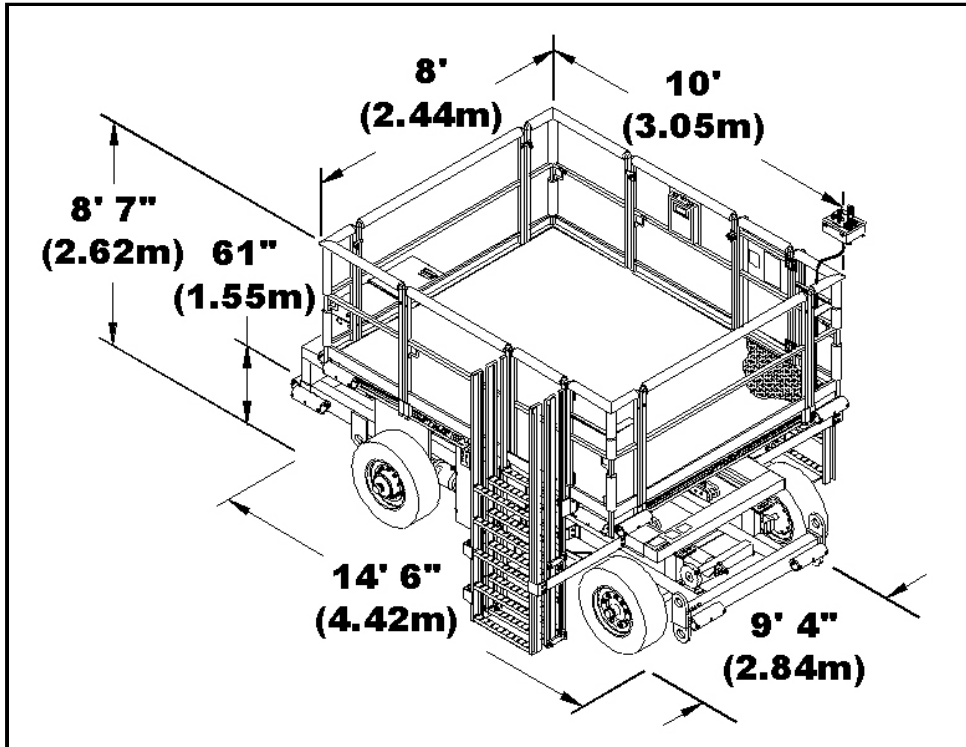

## PERFORMANCE

Travel Speed – Fully Proportional  
0 – 3 mph (0 – 4.83 k/hr)  
Travel Speed at Elevation – Fully Proportional  
0 – 0.5 mph (0 – 0.80k/hr)  
Gradeability – 10%  
Platform Lift/Lower Speed – 0.40 ft/sec (0.12 m/sec)  
\*Lift/Lower speed may vary according to load  
Maximum Platform Height – 14' 6" (4.42m)  
Maximum Working Height – 20' 6" (6.25m)  
Guardrail Height – 42" (1.07m)  
Maximum Platform Capacity – 2,250 lbs (1,020.6 kg)

## FEATURES

110VAC Circuit to Platform  
½" Service Air Line to Platform  
Platform Extension Ladders  
Standard Paint – Gray with Yellow Rails  
Wheels with Rubber Tires – 29" X 12.5" (0.74 X 0.32m)  
Brakes – Automatic Upon Release of Controls

## BATTERY INFORMATION

(1) 36 Volt Industrial Battery Capable of 8-Hours Operation with On Board Fully Automatic Charger  
**Emergency Battery System**  
(4) 6 Volt Deep Cycle Batteries for 24 Volt Backup System with Separate On Board Charger

## OPTIONAL EQUIPMENT

- Flashing Warning Lights
- Turbine Cradle
- Fuel Pod Cradle with X – Y Positioner
- Motion Alarm
- Air Line to Platform
- Platform Mounted Work Lights
- Padded Rails
- Aircraft Bumpers
- Towing Kit
- Custom Paint
- Lifting Lugs

## SAFETY FEATURES

- Scissor Spreader
- Self Closing, Self Latching Gates
- 42" (1.07m) Guardrails with Midrail and Toe Board
- Emergency Stop Button at Each Control Station
- Emergency Backup Lowering System
- Lanyard Attachment Points
- Non-skid Flooring on Foot Traffic Areas
- Speed Limited When is Platform Raised
- Deadman Controls
- Horn

# LIFT-A-LOFT